

STANDARD AIRCRAFT CHARACTERISTICS
SNJ-4,-5,-6 "TEXAN"

BUREAU OF AERONAUTICS
NAVY DEPARTMENT

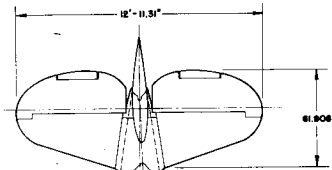

WING AREA - 253.73 SQ. FT.
WING SECTION
N.A.C.A. 2215 - 4412
M.A.C. - 76.0
ASPECT RATIO 7.0

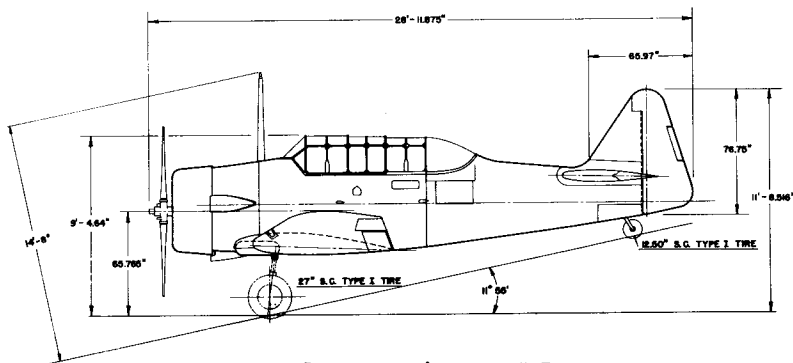
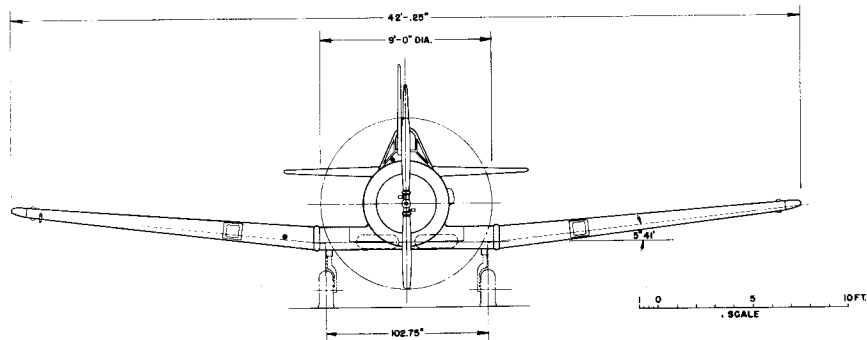
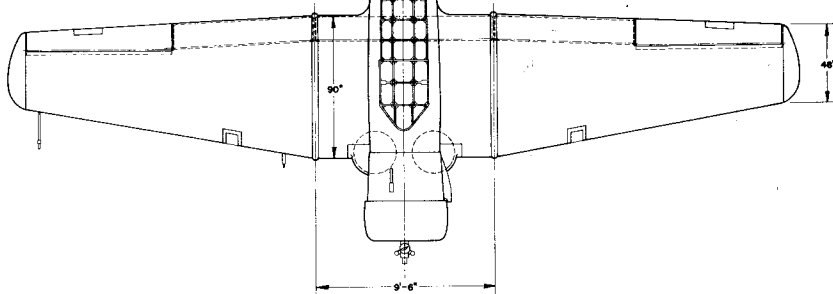

DESCRIPTIVE ARRANGEMENT

3
19
125

MISSION AND DESCRIPTION

All-purpose trainer. Originally procured by Army Air Force for Navy (Navy version of AT-6) for intermediate and instrument flight training. Now used as primary and basic trainer and for pilot's flight proficiency.

Conventional design, two place tandem, low wing, all metal, single engine, land plane with retractable main landing gear. Manufactured by North American Aviation Corporation.

Wing structure is conventional, with a two-spar system. Split flap is hydraulically actuated. The fuselage is of chrome-molybdenum tube truss to the rear of the aft cockpit, with a wood or metal semi-monocoque structure aft of that. Later aircraft have wood stabilizers.

DIMENSIONS

SPAN.....42'-0"
 LENGTH.....29'-0"
 HEIGHT.....14'-8"
 WING AREA.....253.7 sq. ft.
 M.A.C.....76"
 TREAD.....8'-7"

WEIGHTS

(Load	Lbs.	LF)
EMPTY.....	4143 (-4).....	
	4082 (-5).....	
	4050 (-6).....	
BASIC.....	4201 (-4).....	
	4140 (-5).....	
	4108 (-6).....	
DESIGN....	5600.....	5.22
MAX.T.O...	5500.....	5.30
MAX.LAND..	5500.....	

All weights are actual.

FUEL AND OIL

Gals.	No. tanks-	Location
111	2	Wing
FUEL GRADE...91/96		
FUEL SPEC....AN-F-48		

OIL

CAPACITY (gal).....10
 SPEC.....AN-O-8
 GRADE.....1100-1120

ELECTRONICS

(12 Volt System)(SNJ-4)
 Command.....SCR-AL-183

(24 Volt System)(SNJ-5,-6)
 Command.....SCR-274-()
 Marker beacon.....RC-34B
 or RC-193-()

POWER PLANT

NO. & MODEL...(1) R-1340-AN-1
 MFR.....P&W
 SUPERCH.....1 Stage, 1 Speed
 PROP.GEAR RATIO.....D.D.
 PROP MFR.....Ham. Std.
 PROP DESIGN NO.....6101
 NO.BL./DIA.....2/9'-0"

RATINGS

	Bhp.	@Rpm.	@Alt.
T.O.	600	2250	SL
NORMAL	550	2200	5000'

DATA FROM ENGINE SPEC.
 AN-1051

ORDNANCE

Provisions for:

GUNS

No.	Size	Type	Rds.
1	.30 cal.	cowl	200
1	.30 cal.	rear	500
1	.30 cal.	wing	200

K-3 oblique & vert. camera

Gun camera, in wing

N-3 gun sight

BOMBS

No.	Size	Location
10	20#	wing
4	100#	



PERFORMANCE SUMMARY

LOADING CONDLITION	TRAINER			
TAKE-OFF WEIGHT		5282		
Fuel lbs		666		
Bombs lbs				
Wing/Fower Loading (A) lbs/sq.ft. lbs/ bhp		20.8/9.6		
Stall Speed--Power off kn		55.7		
Stall Speed--Power off - No. Fuel kn		52.1		
Stall Speed--Fower on kn		50.9		
Maximum Speed/Alt (B) kn/ft		178/5100		
Take-off Distance, deck -- calm ft		599		
Take-off Listance, deck kn. ft				
Take-off Listance, Airport ft		1180		
Rate of climb -- sea level (B) ft/min		1400		
Service Ceiling (B) ft		22400		
Time-to-climb 10000 ft. (B) min		8.0		
Time-to-climb 20000 ft. (B) min		25.7		
Combat Range/V av 1500 ft. n.mi/kn		560/97		
Combat Radius/V av ft. n.mi/kn				
LOADING CONDLITION				
GROSS WEIGHT lbs				
Engine power				
Fuel lbs				
Bombs/Tanks				
Max. speed at sea level kn				
Max. speed ft. kn				
Combat speed/Alt. kn/ft				
Rate of climb SL ft/min				
Ceiling for 500 fpm R/C ft				
Time-tc-climb/Alt. min/ft				

NOTES

- (A) BHP at Maximum Critical Altitude
- (B) Normal BHP

Performance is based on flight test. Range is based on engine specification fuel consumption data increased by 5%.

 This airplane is not suited for dive bombing training due to speed limitations

Provisions in left wing for mounting Army W-7 camera gun.

